

ALUMINUM TRAIL ENGINE GUARD

Ref.: 2CP090087A



PAP

Assembly Booklet / Paper collection

Livret de montage / Collecte de papier



LDPE

Mini Zip Bag / Plastic collection

Mini sac zip / Collecte de plastique



PAP

Box / Paper collection

Boîte / Collecte de papier



PAP

Carton Separator / Paper collection

Séparateur de cartons / Collecte de papier



C/PAP

Card Header / Paper collection

Carte d'en-tête / Collecte de papier



LDPE

Plastic Bag Cover / Plastic collection

Couverte de sac en plastique / Collecte de plastique



ASSEMBLY INSTRUCTION / INSTRUÇÃO DE MONTAGEM

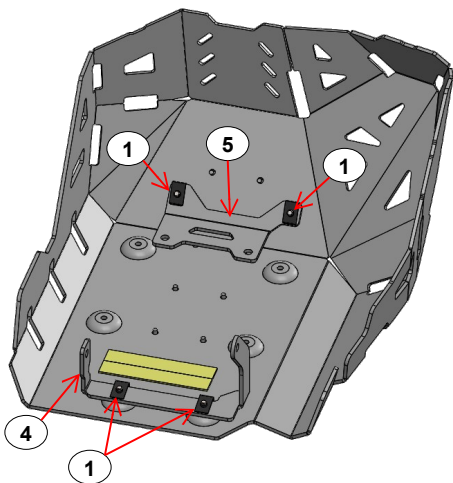
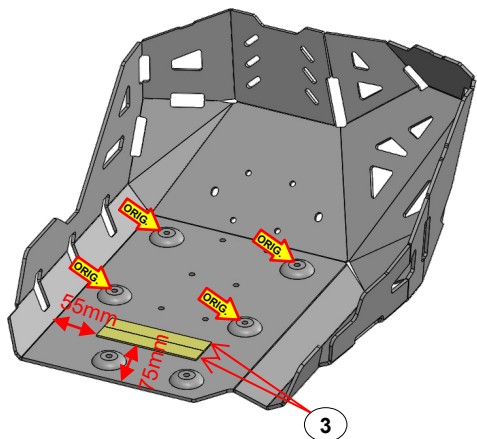
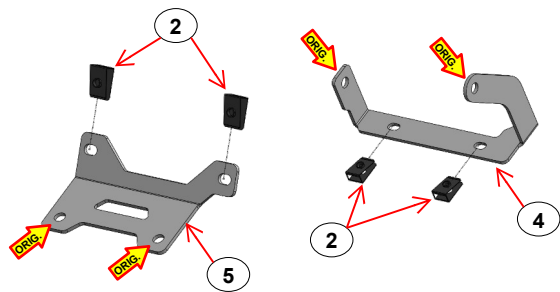

	N.m	M4	M5	M6	M8	M10	M12
STEEL	8.8	2.7	5.5	9.7	23.0	47.0	80.0
STAINLESS STEEL	A2	2.6	5.1	8.7	21.2	42.0	73.0

5	Fixação Inox / Inox Clamp	B87A	1
4	Fixação Inox / Inox Clamp	A87A	1
3	Tela Protetora / Protective Strip	120mm	2
2	Mola de Friso / Clip Inox	M6	4
1	Parafuso / Screw	M6x16 FA ISO7380 A2	4
ITEM Nº:	COMPONENTE (COMPONENT):	DESCRIÇÃO (DESCRIPTION):	QUANT.:
ACESSÓRIOS (ACCESSORIES)			



English:

- Tight all screws.

Français:

- Serrer toutes les vis.

Português:

- Apertar todos os parafusos.

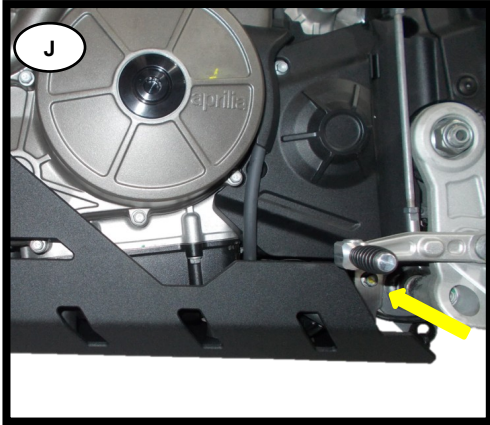

- English:**
- Tighten the origin screw of the fixation.
- Français:**
- Serrer la vis d'origine de la fixation.
- Português:**
- Apertar parafuso de origem da fixação.

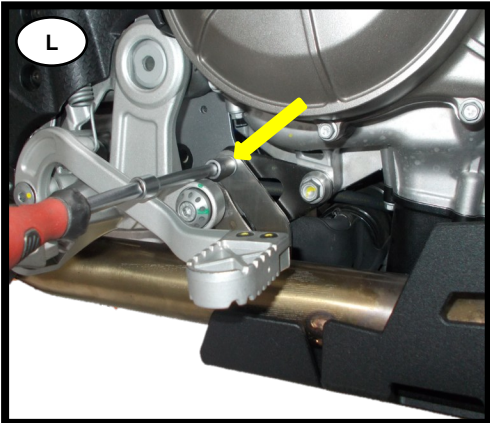

- English:**
- Tighten the origin screw of the fixation.
- Français:**
- Serrer la vis d'origine de la fixation.
- Português:**
- Apertar parafuso de origem da fixação.

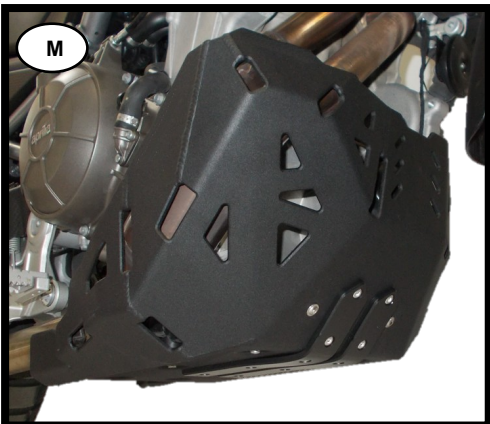

- English:**
- Tight all screws.
- Français:**
- Serrer toutes les vis.
- Português:**
- Apertar todos os parafusos.

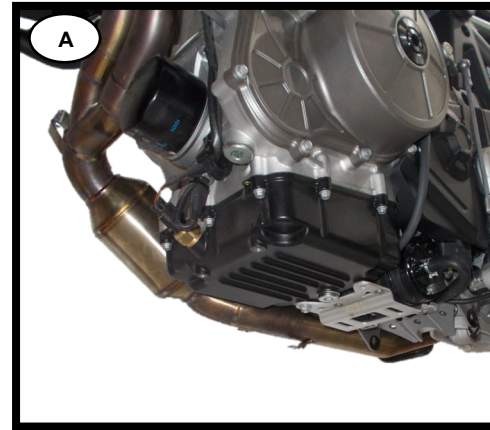

- English:**
- Remove the original protection.
- Français:**
- Retirer le protection d'origine.
- Português:**
- Retirar proteção de origem

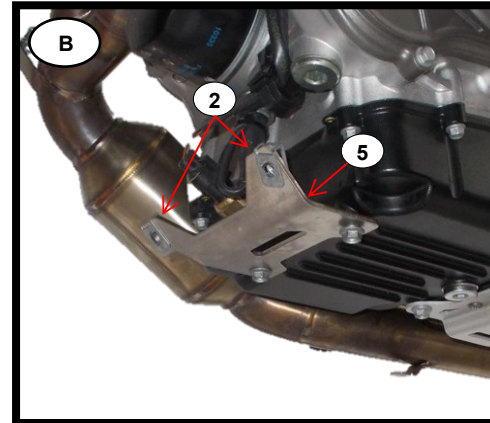

- English:**
- Apply item N°2 (Clip Inox – x2) on item N°5 (Inox Clamp – x1) and mount on the motorcycle with origin screws.
- Français:**
- Appliquer l'item N°2 (Clip Inox – x2) sur l'item N°5 (Fixation Inox – x1) et monter sur la moto avec les vis d'origine.
- Português:**
- Aplicar o item N°2 (Mola de Friso – x2) no item N°5 (Fixação Inox – x1) e montar na moto com os parafusos de origem.

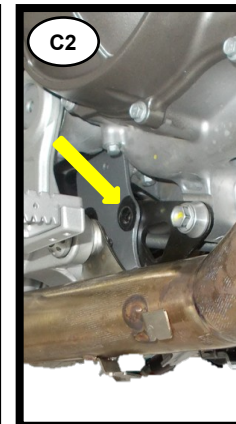

- English:**
- Remove the original Screws (2x) marked in the photo (left side Photo C1 and right side Photo C2).
- Français:**
- Retirez les vis d'origine (2x) marquées sur la photo (côté gauche Photo C1 et côté droit Photo C2).
- Português:**
- Remover os Parafusos de origem (2x) marcados na foto (lado esquerdo foto C1 e lado direito foto C2).

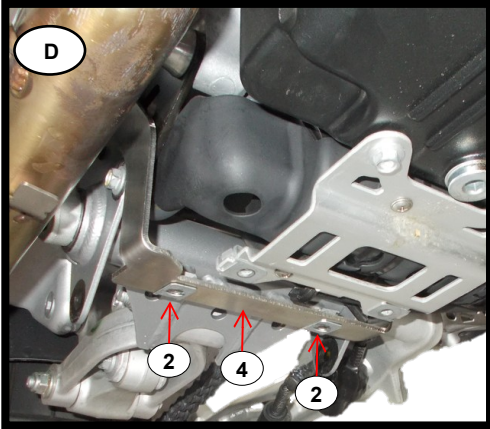

English:

- Apply item N°2 (Clip Inox – x2) on item N°4 (Inox Clamp – x1) and mount on the motorcycle with origin screws.

Français:

- Appliquer l'item N°2 (Clip Inox – x2) sur l'item N°4 (Fixation Inox – x1) et monter sur la moto avec les vis d'origine.

Português:

- Aplicar o item N°2 (Mola de Friso – x2) no item N°4 (Fixação Inox – x1) e montar na moto com os parafusos de origem.

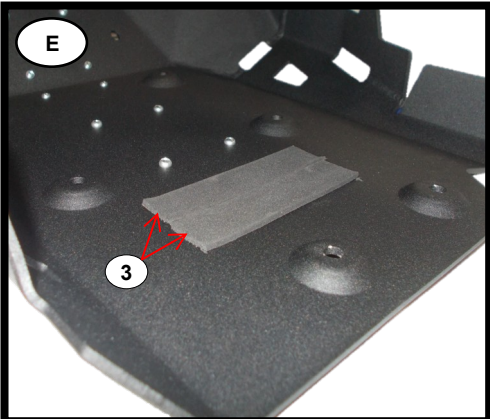

English:

- Apply item N°3 (Protective Strip – x2) according to the assembly instruction.

Français:

- Appliquer l'item N°3 (Bande de Protection – x2) selon les instructions de montage.

Português:

- Aplicar o item N°3 (Tira Protetora – x2) de acordo com a instrução de montagem.

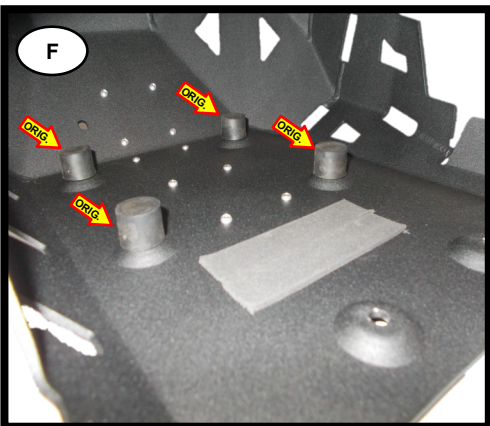

English:

- Apply original silent block and nut on the protection (4x).

Français:

- Appliquer le silentbloc et l'écrou d'origine sur la protection (4x).

Português:

- Aplicar sinobloco e porca de origem na proteção (4x).

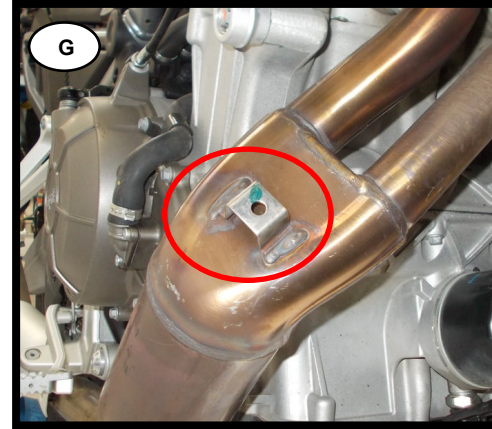

English:

- Remove origin clip inox.

Français:

- Retirer clip inox origine.

Português:

- Remover mola de friso de origem.

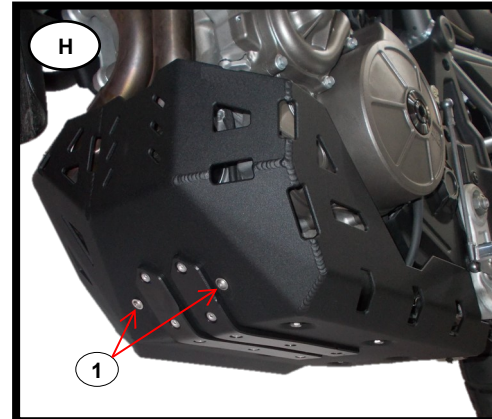

English:

- Mount protection on the motorcycle and apply item N°1 (Screw – x2).

Français:

- Monter la protection sur la moto et appliquer l'item N°1 (Vis – x2).

Português:

- Montar proteção na moto e aplicar o item N°1 (Parafuso – x2).

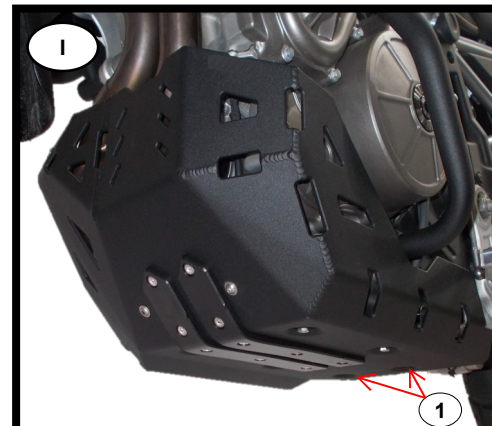

English:

- Apply item N°1 (Screw – x2).

Français:

- Appliquer l'item N°1 (Vis – x2).

Português:

- Aplicar o item N°1 (Parafuso – x2).